

SOFIA PROFESSIONAL 36"

36" ALL GAS PROFESSIONAL RANGE



CODE ID



F6PGR366S2



Heavy Duty Grates



Continuous Grate Surface



Dual Crescendo Burner



Dual Convection



Soft Closing Door



Cool Touch Door



Multi-level cooking



1 Telescopic Rack



Digital Controls



Nova Broiler System

COLOR KIT

	STAINLESS STEEL
	MATTE BLACK RAL 9004
	GLOSSY BLACK RAL 9004
	GLOSSY RED RAL 3003
	GLOSSY WHITE RAL 9016
	MATTE WHITE RAL 9016
	MATTE GREY RAL 9007



OPTIONAL ACCESSORIES

PDRKIT36 ...	Color kit
FMWOK	Wok ring
FMSIM	Simmer plate
F6BG36BCI	Island trim
F6BG36STD	Standard trim
F6BG36HBT	High back trim
FMGRID36	36" Griddle
FMTRP36	Telescopic rack

SPECIFICATIONS

COOKING SURFACE

3 Heavy Duty, continuous cast iron grates
One piece, matte finish porcelain burner bowl
6 Dual-Flame Crescendo Burners
2 X 20,000 BTU max (NG)
4 X 18,000 BTU max (NG)
Natural Gas (LP convertible)

NOVA BROILER SYSTEM

Intense heat sears meats and fish locking in juices, with large broiling area. Ventilation in our All Gas Pro Ranges allows for closed door broiling, which ensures constant cooking.

OVEN

Dual Convection
Oven temperature electronic control
Nova Broiler System
Black Porcelain enamel interior
Cool to the touch soft closing door
Extra-large baking cavity and viewing area
3 Halogen lights for flawless visibility
Total capacity 147,2 lt.
Total capacity 5,20 cu. ft.
2 chrome racks
Enameled Broiler Pan

OVEN FUNCTIONS

Bake
Broil
Convection
Pizza cooking mode 590 °F
Dehydrate
Timer
Sabbath Mode

SOFIA

ALL GAS PROFESSIONAL RANGE

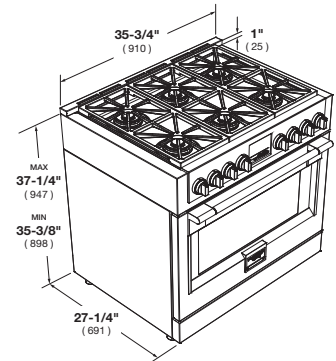

CODE ID	36" ALL GAS PROFESSIONAL RANGE - F6PGR366S2	
Series	600	
Finish	Professional Design - Stainless Steel	
CONTROL PANEL		
Control Type	8 Heavy Duty Knobs	
Display: Temperature - Function	White LED	
Ignition/Temperature control	Electronic Control (min/max 170/550°F)	
COOKTOP		
Type	GAS (NG or LP)	
Cooking Surface	Matte Black Enamel	
GAS COOKTOP FEATURES		
Electric Re-ignition system	•	
Flame-out sensing	•	
Top Mount Injectors	•	
L.P. Conversion Kit	•	
Dual Crown Brass Burner	•	
Heavy Duty Cast Iron Grates	3	
Cooking Zones	6	
Burners types	All Dual Flame/Simmer Burner	
Power Front-L,Front-R (Max/Min) NG	20000 (BTU/h) - 5900W / 750 (BTU/h) - 220W	
Power Front-R (Max/Min) NG	-	
Power (Max/Min) NG	18000 (BTU/h) - 5300W / 750 (BTU/h) - 220W	
Power (Max/Min) LP	15000 (BTU/h) - 4400W / 750 (BTU/h) - 220W	
OVEN		
Type	Gas - Dual Convection	
Temperature Regulation	Electronic thermostat control	
OVEN FUNCTIONS		
	Bake	
	Broil	
	Pizza	
GAS OVEN FEATURES		
	Electronic Flame Ignition	
	Flame-out Sensing	
	Flame-out Auto-off	
	Sabbath Mode	
	L.P. Conversion Kit	
OVEN DOOR(S)		
Oven Glass Window	Deep Embossed Extra Wide Window	
Door Cooling System	4 Heat Resistant Glasses	
Door Hinges - Soft-closing System	Heavy Duty Steady Tilt	
Handle Style	Stainless Steel Tube with Metal End caps	
OVEN CAVITY		
Total Capacity (lt)	147,2	
Total Capacity (cu. ft.)	5,20	
Usable Capacity (cbft)	4,4	
Cavity Enamel Color	Black	
Rack Positions	6	
Oven Lights	3x20W Halogen	
NOVA BROILER SYSTEM BURNER		
Power (Max) NG	18000 (BTU/h) - 5300W	
Power (Max) LP	17000 (BTU/h) - 5000W	
BAKE BURNER		
Power (Max) NG	21500 (BTU/h) - 6300W	
Power (Max) LP	21500 (BTU/h) - 6300W	
OVEN ACCESSORIES		
Chrome Racks	2	
Enameled Broiler Pan (basin + anti splash)	1	
Telescopic Chrome Rack	1	
DIMENSIONS/WEIGHT		
Overall dim - Width	35 - 3/4"	910 mm
Overall dim - Height (min - max)	35 - 3/8", 37 - 1/4"	898 mm - 947 mm
Overall dim - Depth	29 - 3/4"	756 mm
Gross Weight	377 lbs	171 kg
POWER / RATINGS (120 V, 60 HZ)		
Watts / Amps	600W - 2A	
Power Cable	Nema 5-15P	
INSTRUCTIONS FOR USE		
Use & Care Manual / Installation Manual	English / French / Spanish	