

DSIGN HOODS

# CHB 9012 X



External dimension  
80 cm



Stainless Steel



Concealed installation



Perimeter extraction



Filtering



Suction



Noise level:  
47/-60 dBA



LED lighting



Automatic cut off timer



Suction Power (max)  
592 m<sup>3</sup>/h

## CANOPY EXTRACTOR

Stainless steel finish  
Energy Class B

## PERFORMANCE

Perimeter extraction  
Suction power up to 592 m<sup>3</sup>/h  
4 extraction speeds  
Sleep timer  
Extraction function  
pre-configured for filters  
Sound level 47/-60 dBA

## FEATURES

Built-in Hood  
Push controls  
LED lighting  
Internal aluminium anti-grease filter  
with steel borders  
Rated power 235W  
Air outlet minimum Ø 150 mm  
Non-return air valve (extraction)

## STANDARD ACCESSORIES

Power cable

## OPTIONAL ACCESSORIES

KITCF 003:  
charcoal filters for filtering version

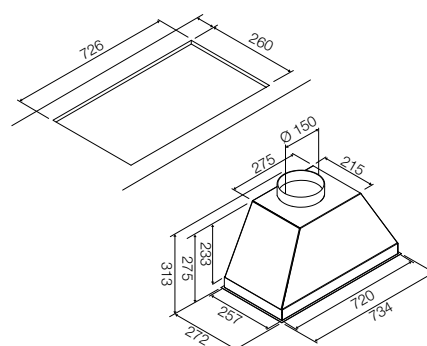

Stainless steel  
**CHB 9012 X**  
Code EAN 8019801013388



Set of no. 1 carbon filters  
**KITCF003**  
Code EAN 8019801015061