

LIFT HOODS

## CHDD 12010 RC X

STAINLESS STEEL



External dimension identifier



Downdraft System



Energy Class Efficiency



Noise level: 42/-59 dBA



Over-top installation



Perimeter extraction



LED lighting



Remote control



Steel filters



Extraction Capacity (max) 730 m<sup>3</sup>/h

### HOOD WITH DOWNDRAFT SYSTEM

Stainless steel finish  
Energy Class A

### PERFORMANCE

Perimeter extraction  
Suction power up to 730 m<sup>3</sup>/h  
4 extraction speeds  
Extraction function pre-configured for filters  
Sound level 42/-59 dBA

### FEATURES

Rated power 285W  
Led strip lighting  
Internal anti-grease filters in aluminium with steel borders  
Air outlet minimum Ø 150 mm

### STANDARD ACCESSORIES

Remote control  
Power cable

### OPTIONAL ACCESSORIES

KITCF 005: carbon filters for filtering version (see page 240)

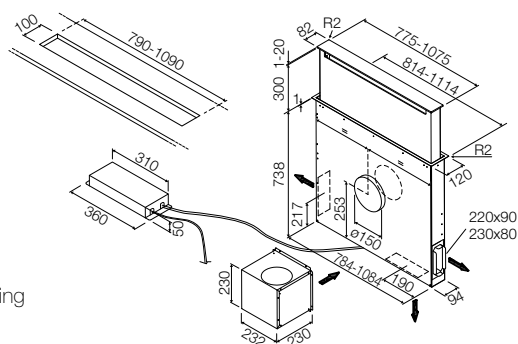

### AVAILABLE MOTORS

DDM Installation on-board hood  
DDMA Remote installation  
DDME External installation



On board motor  
**DDM**

Code EAN 8019801013395



Remote motor  
**DDMA**

Code EAN 8019801015191



External motor  
**DDME**



Stainless steel  
**CHDD 12010 RC X**  
Code EAN 8019801013326



Set of no. 2 carbon filters  
**KITCF005**  
Code EAN 8019801015085