

FBCD 362 NF ED

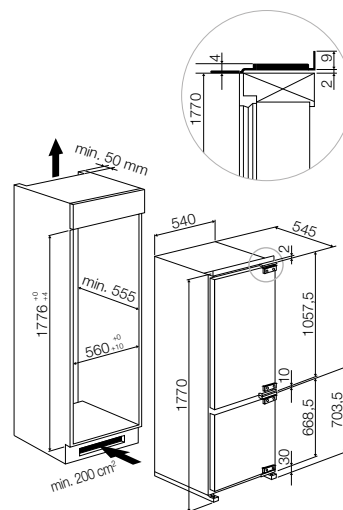

BUILT-IN COMBINATION

- Flat hinges
- Energy Class A++
- Total net capacity 282 litres
- Electronic display with sensor controls
- LED lighting
- Fan for forced cold (AIR+)
- NO-FROST system in freezer compartment
- 2 separate temperatures displayed
- 2 separate cooling circuits
- Anti-bacterial inner coating
- 4 tempered safety-glass shelves one of which can be divided
- Metal bottle rack
- Drawers and door shelves with metal inserts
- 1 Zero (0°C) drawer
- 3 transparent drawers in freezer compartment
- "RAPID CHILL" command
- "RAPID FREEZE" command
- Door open alarm system
- Automatic defrosting
- Reversible door (standard installation on right)
- Climate class: SN,ST,N,T



Flat hinges
FBCD 362 NF ED
 Code EAN 8019801015573