

30" LARGE OVEN

FCO 300 P TM 2F X



-  Fingerprint proof stainless steel
-  Digit Control
-  Multi-level cooking
-  Cool Door < 50°C
-  Automatic cooking
-  Telescopic Rails 2 levels
-  BOOST rapidly reach pre-selected temperature
-  Automatic self-cleaning with PYROLYSIS
-  Temperature measurement probe
-  Internal Capacity: 123 litres
-  FREE NICKEL Nickel free enamel
-  Energy Class Efficiency A

XXL SELF-CLEANING ELECTRONIC MULTIFUNCTION OVEN

CREACTIVE operating system
Finish: Fingerprint resistant stainless steel
Energy Class A

PERFORMANCE

15 cooking modes
Automatic cooking with Pre-selected, customizable recipes (weight, cooking time and temperature)
BOOST to rapidly reach the pre-selected temperature
PYROLYSIS Self-cleaning 2 cycles)

FEATURES

Control panel with touch controls
Dual convection fan
Black Porcelain enamel interior
Internal lighting with 3 light spots
Internal capacity 123 litres

SAFETY

Cool door (< 50°C) with 4 panes of glass
2 speed tangential cooling ventilation
Keypad and door safety lock function
Smoke catalyst

STANDARD ACCESSORIES

Meat probe
food temperatures
2 fully removable chrome telescopic racks,
1 wide enamelled tray with anti-splash insert
2 flat grill racks
Power cable

ACCESSORIES ON REQUEST

FK 30" X frame for column installation with Compact 45

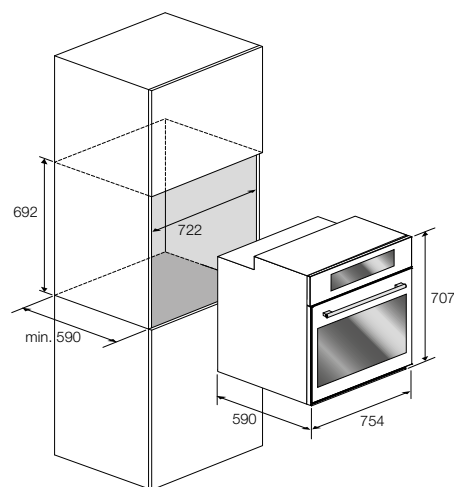

Fingerprint resistant stainless steel
FCO 300 P TM 2F X
Code EAN 8019801017300



30" stainless steel frame for Compact 45
FK 30" X
Code EAN 8019801014729