

DESIGN HOODS

FQH 900 X - FQH 1200 X



WALL-MOUNTED HOODS

Steel finish
Energy Class A

PERFORMANCE

Suction power up to 787 m³/h (90 cm) and 825 m³/h (120 cm)
4 extraction speeds
Auto power off
Extraction function pre-configured for filters
Sound level 54-67 dBA (90 cm) and 51-62 dBA (120 cm)

FEATURES

Soft touch
LED lighting
Internal aluminium anti-grease filters
Rated power 280W
Air outlet minimum Ø 150 mm
Non-return air valve (extraction)

STANDARD ACCESSORIES

Power cable

OPTIONAL ACCESSORIES

KITCF 009: charcoal filters for filtering version

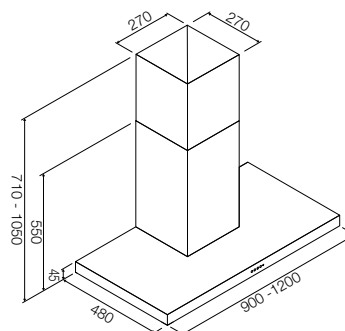

Stainless steel
FQH 900 X
Code EAN 8019801015726



Stainless steel
FQH 1200 X
Code EAN 8019801015733



Set of 2 charcoal filters
KITCF009
Code EAN 8019801015863