

# FRSI 400 F ED X

FRIDGE

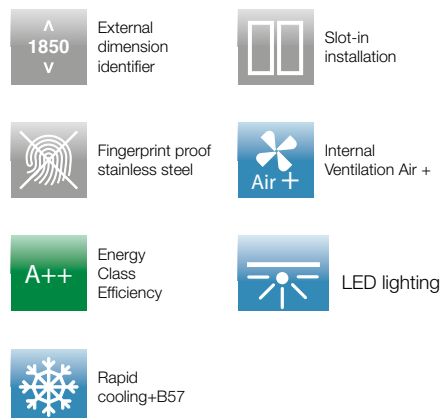

## SINGLE DOOR REFRIGERATOR SLOT IN INSTALLATION

- Energy Class A++
- Stainless steel door with handle
- Right-hand (non-reversible) hinge
- Total capacity 352 litres
- LCD electronic display with sensor controls
- Control for "RAPID CHILL"
- Control for "VACATION FUNCTION"
- Door open alarm system
- Internal LED lighting
- Forced cold air fan (AIR+)
- Anti-bacterial inner lining
- 6 tempered safety-glass shelves, height adjustable
- Metal bottle rack
- 5 shelves on inside of door
- Egg tray
- 2 fruit and vegetable drawers
- 1 large drawer
- Automatic defrosting

## STANDARD ACCESSORIES

Seal for joining with Freezer FFSI 350 NF ED X

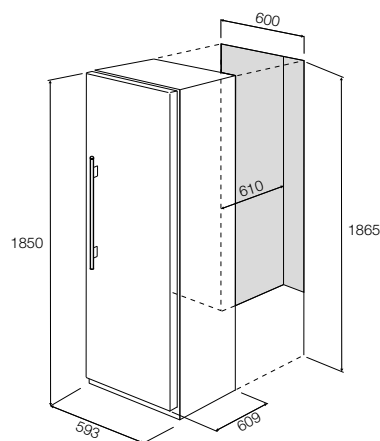

Stainless steel door  
**FRSI 400 F ED X**  
Code EAN 8019801014613