

OVEN 100 SERIES 30"



CODE ID

30" MULTIFUNCTION EASY-CLEAN OVEN

F1SM30S1



-  Defrost
-  Multi-level cooking
-  Cool Touch Door
-  Interior Lighting

OVEN

Knob and electronic controls
Black Porcelain enamel interior
2 Halogen lights
Gross capacity 3.0 cu. ft.
2 chromed racks
Enameled Grill basin

OVEN FUNCTIONS

Convection Broil
Convection Roast
Bake
Broil
Pizza (Lower Conv. Bake)
Lower Bake
Thaw (Defrost)

OPTIONAL ACCESSORIES

FMTR 130 Telescopic rack

DISTINTO

30" MULTIFUNCTION EASY-CLEAN OVEN

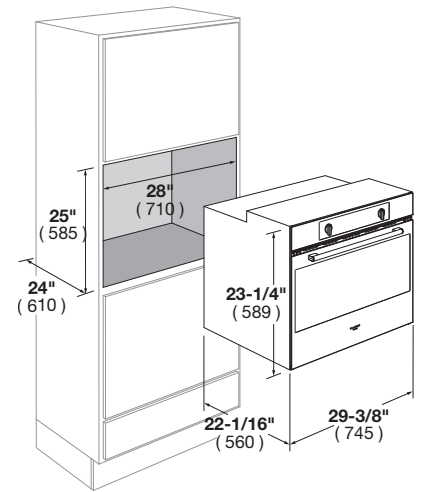

CODE ID	F1SM30S1 - 30" MULTIFUNCTION EASY-CLEAN OVEN	
Series and Finish	100 Series - Stainless Steel	
CONTROL PANEL		
Control Type	2 Knobs/6 Buttons	
Display: Clock - Timer	Red LED	
OVEN		
Type	Electronic	
Temperature Regulation	Electro-Mechanical Control (min/max 120/540°F - 50/285°C)	
OVEN FUNCTIONS		
	Convection Bake	Thaw (Defrost)
	Convection Broil	Lower Bake
	Convection Roast	Oven Lights
	Pizza (Lower Convection)	Broil
	Bake	
OVEN DOOR(S)		
Oven Glass Window	Large See Through Glass	
Door Cooling System	3 Heat Resistant Glasses	
Door Hinges	Heavy Duty Steady Tilt	
Handle Style	Tubular Steel	
OVEN CAVITY		
Gross Capacity (cbft)	3.0	
Usable Capacity (cbft)	2.8	
Cavity Enamel Colour	Black	
Rack Positions	4	
Oven Lights	2x20W Halogen	
HEATING ELEMENTS (@240V)		
Broil Upper Heating Element	3100 W	
Upper Auxiliary Element	1032 W	
Lower Auxiliary Element	-	
Concealed Bake Lower Heating Element	2100 W	
Convection Element	-	
OVEN ACCESSORIES		
Chromed Racks	2	
Enameled Broiler Pan (basin + anti splash)	1 (basin only)	
Telescopic Chromed Rack	-	
DIMENSIONS/WEIGHT		
Overall dim - Width	29 - 3/8"	(745 mm)
Overall dim - Height	23 - 3/16"	(589 mm)
Overall dim - Depth	22 - 1/16"	(560 mm)
Cut-out - Width	28"	(710 mm)
Cut-out - Height (min)	23"	(585 mm)
Cut-out - Depth (min)	24"	(610 mm)
Gross Weight	148 lbs	(67 kg)
POWER / RATINGS (208/240 V, 60 HZ)		
kW / Amps rating at 120-240V, 60Hz	3.63kW - 15.6A	
kW / Amps rating at 120-208V, 60Hz	2.76kW - 13.7A	
Power Cable	Conduit	
INSTRUCTIONS FOR USE		
Use & Care Manual / Installation Manual	English / French / Spanish	