

# OVEN 100 SERIES 30"



CODE ID

30" MULTIFUNCTION SELF-CLEAN OVEN

**F1SP30S1**



-  True Convection
-  Self Clean Oven
-  Multi-level cooking
-  Cool Touch Door
-  Interior Lighting

## OVEN

Knob and electronic controls  
True Convection  
Self-cleaning oven with Multifunction baking  
Black Porcelain enamel interior  
2 Halogen lights  
Gross capacity 3.0 cu. ft.  
2 chromed racks  
Enameled Broiler Pan (basin + anti splash)

## OVEN FUNCTIONS

Convection Bake  
Convection Broil  
Convection Roast  
Bake  
Broil  
Thaw (Defrost)  
Self-Clean

## OPTIONAL ACCESSORIES

FMTR 130      Telescopic rack

# DISTINTO

30" MULTIFUNCTION SELF-CLEAN OVEN

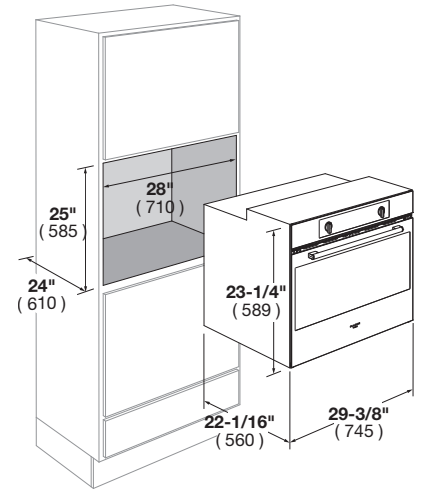

CODE ID	F1SP30S1 - 30" MULTIFUNCTION SELF-CLEAN OVEN	
Series and Finish	100 Series - Stainless Steel	
<b>CONTROL PANEL</b>		
Control Type	Electronic	
Display: Clock - Timer - Temperature	Red LED	
Language	English	
<b>OVEN</b>		
Type	Electronic	
Temperature Regulation	Electronic Control (min/max 120/485°F - 50/250°C)	
<b>OVEN FUNCTIONS</b>		
	Pyrolytic Self-Clean	Bake
	True Convection	Thaw (Defrost)
	Convection Bake	Oven Lights
	Convection Broil	Broil
	Convection Roast	
<b>GAS OVEN FEATURES</b>		
	Temperature Display °C/°F	
<b>OVEN DOOR(S)</b>		
Oven Glass Window	Large See Through Glass	
Door Cooling System	4 Heat Resistant Glasses	
Door Hinges	Heavy Duty Steady Tilt	
Handle Style	Tubular Steel	
<b>OVEN CAVITY</b>		
Gross Capacity (cbft)	3.0	
Usable Capacity (cbft)	2.8	
Cavity Enamel Colour	Black	
Rack Positions	4	
Oven Lights	2x20W Halogen	
<b>HEATING ELEMENTS (@240V)</b>		
Broil Upper Heating Element	3100 W	
Upper Auxiliary Element	1032 W	
Lower Auxiliary Element	600 W	
Concealed Bake Lower Heating Element	1400 W	
Convection Element	2500 W	
<b>OVEN ACCESSORIES</b>		
Chromed Racks	2	
Enameled Broiler Pan (basin + anti splash)	1	
Telescopic Chromed Rack	Optional	
<b>DIMENSIONS/WEIGHT</b>		
Overall dim - Width	29 - 3/8"	(745 mm)
Overall dim - Height	23 - 3/16"	(589 mm)
Overall dim - Depth	22 - 1/16"	(560 mm)
Cut-out - Width	28"	(710 mm)
Cut-out - Height (min)	23"	(585 mm)
Cut-out - Depth (min)	24"	(610 mm)
Gross Weight	148 lbs	(67 kg)
<b>POWER / RATINGS (208/240 V, 60 HZ)</b>		
kW / Amps rating at 120-240V, 60Hz	3.63kW - 15.6A	
kW / Amps rating at 120-208V, 60Hz	3.53kW - 17.4A	
Power Cable	Conduit	
<b>INSTRUCTIONS FOR USE</b>		
Use & Care Manual / Installation Manual	English / French / Spanish	