

FBC 342 TNF ED

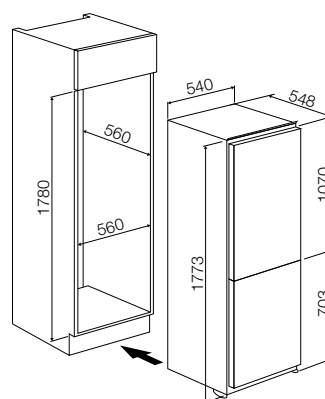

BUILT-IN COMBINATION

- Drag hinges
- Energy Class A+
- Total net capacity 282 litres
- Electronic display with sensor controls
- LED lighting
- Fan for forced cold (AIR+)
- TOTAL NO-FROST System
- 2 separate temperatures displayed
- 2 separate cooling circuits
- Anti-bacterial inner coating
- 4 tempered safety-glass shelves one of which can be divided
- 2 drawers for fruit and vegetables
- Drawers and holders with metal inserts
- 3 transparent drawers in freezer compartment
- "RAPID CHILL" command
- "RAPID FREEZE" command
- Door open alarm system
- Automatic defrosting
- Reversible door (standard installation on right)
- Climate class: SN,ST



Sliding system
FBC 342 TNF ED
 Code EAN 8019801014637