

FBC 4500 TC X

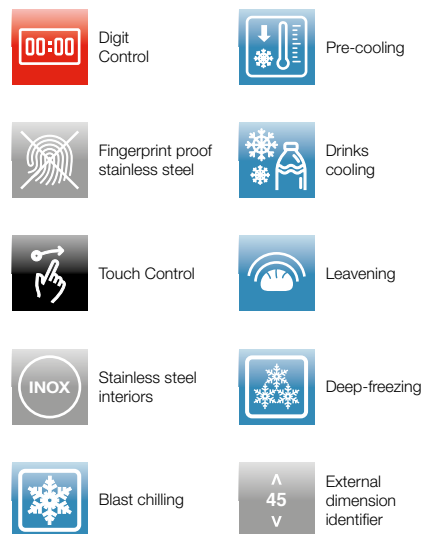

MULTI FUNCTION BLAST CHILLER

Touch proof stainless steel

PERFORMANCES

11 functions

Temperatures from +75°C to -30 °C

Blast chilling (+ 3 °C) for 5 to 7 days

food conservation in the refrigerator

Deep freezing (-18 °C) for a few

months food storage

Pre-Cooling: runtimes optimization

programs

Cooling: accelerating lowering

temperature for freshly cooked food

Beverages: lowering temperature

in a given time

Storage at 0 °C: to preserve

foods properties for several

hours before cooking

Sanitizing (Raw Fish) abatement

process temperature at -30 °C

for preventing the formation

of bacteria in food to consume raw

Thawing: defrosting from 1-3 °C

temperature without starting

to cook the food

Ready to serve: heating cooked food

and kept in the refrigerator up to the

consummation temperature

Slow cooking (Slow cooking): cooking at a constant temperature for desired time , keeps the quality and tenderness of the food.

Leavening: the dough with controlled temperature and humidity

FEATURES

TFT Touch controls

Programming values of

the individual functions

Stainless steel interior

LED lighting

Inner capacity of 40 litres

SAFETY

Protection with sensors

against temperature overloads

STANDARD ACCESSORIES

Core probe

Glass tray with high thermal resistance

(the same of 60 cm ovens)

Flat metal rack

COMBINATION OPTIONS

All appliances of the series COMPACT 45 and SPECIAL 45 in stainless steel

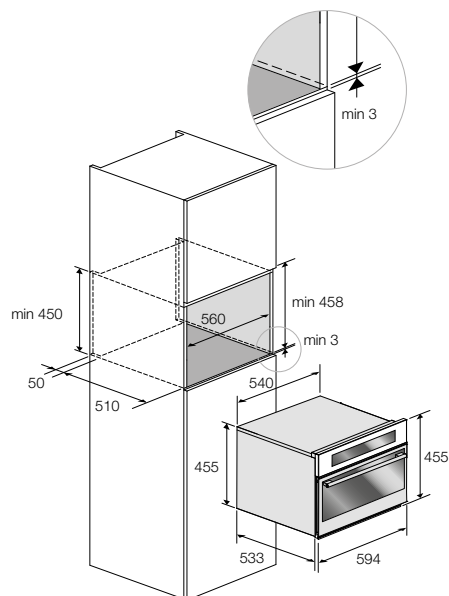

Touch proof stainless steel

FBC 4500 TC X

Code EAN 8019801016822