

ARIA+ INDUCTION HOB 80



CODE ID

INDUCTION HOB WITH CENTRAL ASPIRATION

FCLH 8041 HID TS BK



- Flush-Top Installation
- Semi-Flush Top Installation
- Slide Touch Control
- Glass Ceramic Surfaces
- Temperature Sensor
- Residual Heat System
- Power Booster
- Timer
- Flexi Zone
- Pan Detection System

FEATURES

Touch slider controls
Possibility of mounting even on top-level
Pans detection sensor
Safety switch (accidental use prevention)
Residual heat indicator (H)
Automatic shutdown
with temperature sensor
Black steel central grid
Suction power; 800 m³/h
Sound level: from 49 to 71 dBA
Energy efficiency class: A+

PERFORMANCES

4 cooking zones
2 Vertical Flexi zones,
on the sides, for larger pans
bi-directional central vertical
hood with black steel cover
Rapid heating booster
Automatic heating
Keep warm
End of cooking timer
Upright hood two-sides venting

SERIES ACCESSORIES

Scraper for surface cleaning

CLUSTER

INDUCTION HOB WITH CENTRAL ASPIRATION

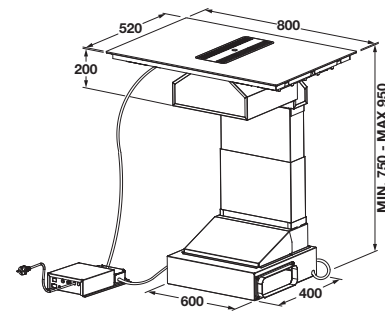

FCLH 8041 HID TS BK - INDUCTION HOB WITH CENTRAL VENTING	
Finishing	Cera Black ceramic
INDUCTION PERFORMANCES	
Octogonal Ø 290/180 DUAL	2100/3700 (x4) W
Octa Solo	-
Octa 2 Flexi	-
Octa 3 Flexi	-
Ø 145	-
Max absorbed power (W)	7360 W max
Assisted cooking: 42°C Fusion	•
70°C Slow cooking	•
90°C Simmering	•
INDUCTION CONTROLS	
Slider touches	•
Automatic cooking start	•
Timer for every zone	•
Residual heat indicator	•
Acoustic beep	•
Lock safety key	•
Power levels	9+P
Visual digit display	•
HOOD FEATURES	
Energy efficiency class	A+
Speed levels	4
Auto cut-off	•/10 minuts
Grease filter reset warning light	•
Charcoal filter warning light	•
Grease filters material	Stainless steel
Dishwashable graze filters	•
Ø Duct diameter mm/flat pipes	Ø 150mm / rect. 220x90 (230x80)
Non return flap	•
Charcoal filter for filtering version	FHCF 17
Digital display / Control type	Front / Touch keys
Output (max) m³/h	800
Sound level (dBA)	54-68
Yearly energy consumption (kWh)	47
Motor power (W)	110
INDUCTION ACCESSORIES	
Ceramic scraper	•
Cord	•
DIMENSIONI	
Width x Depth	(780 x 520) mm
Cut-out (WxD)	(750 x 490) mm