



Sliding Telescopic Rails



Leavening



Slow Cooking



Warming Function



Timer

## FEATURES

Obsidian black glass finish of front  
Touch control panel  
Welding bar  
Glass lid  
Vacuum chamber tank  
Energy saving function  
Pump oil dehumidification cycle (20 min)

## MODES

CHEF Function  
Increased storage time for individual foods  
Empty cycle for storage (with envelopes)  
Empty cycle for cooking (with bags)  
Empty cycle in the containers - short  
Empty cycle in the containers - long  
Vacuum cycle for jars outside the tank

## SERIE ACCESSORIES

Storage bags (in PA / PE) 10 units  
Baking bags (in OPA / PP) 10 units,  
cooking at temp. max. 100 ° C

## ACCESSORIES ON REQUEST

External vacuum containers  
Suction device (external containers)

## COMPATIBLE WITH:

With the COMPACT 45 ovens and  
SPECIAL 45 models with obsidian  
black finish

# CLUSTER

## VACUUM SEALING DRAWER

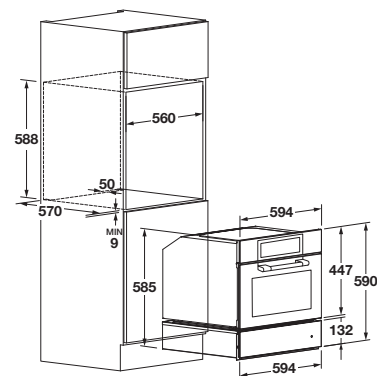

FCLVSD 150 TC BK	
Type	Vacuum sealing drawer
Finishing	Obsidian black glass
Inner sleeve:	Stainless Steel
<b>MAIN FEATURES</b>	
Opening type	Push to Open
Programming	Touch key
Functions	4
Max vacuum level	2-10 mbar( 99,9%)
Usable inner capacity (litres)	7 L
Chamber height	95 mm
Lid opening	65°
Removable sealing bar lenght	260 mm
CHEF cycle	•
Cooking bag sealing cycle time	55"
Preservation bag sealing cycle time	3/70"
Vacuum in outer container	•
Bags max dimensions in cm	25 x 35
Oil refill warning light	•
Oil dehumidification cycle	•
<b>POWER RATINGS</b>	
Max absorbed power (W)	230W
Tension and frequency (V-Hz)	230-50/60
Cord/ plug type	•/Schuko
<b>PRODUCT DIMENSIONS</b>	
Width mm	548
Height mm	135
Depth mm	544
Cut-out (WxHxD) mm	560x140x560