

ACCENTO PROFESSIONAL 36"

36" DUAL FUEL PROFESSIONAL RANGE



CODE ID



F4PDF366S1



Heavy Duty Grates



Continuous Grate Surface



Dual Crescendo Burner



Dual Convection



Self Clean Oven



Multi-level cooking



Cool Touch Door



Digital Controls

COLOR KIT

	STAINLESS STEEL	
	MATTE BLACK	RAL 9004
	MATTE WHITE	RAL 9016
	GLOSSY RED	RAL 3003

OPTIONAL ACCESSORIES

ACDKIT36 ...	Colour kit
FMWOK	Wok ring
FMSIM	Simmer plate
F6BG36BCI	Island trim
F6BG36STD	Standard trim
F6BG36HBT	High back trim
FMGRID36	Griddle
FMTRP36	Telescopic rack

COOKING SURFACE

3 Heavy Duty, continuous cast iron grates
One piece, matte finish porcelain burner bowl
3 Dual-Flame Crescendo Burners
3 X 18,000 BTU max (NG)
3 Rapid Burners
3 X 15,000 BTU max(NG)
Natural Gas (LP convertible)

OVEN

Dual True Convection
Self-cleaning oven with Multifunction baking
Black Porcelain enamel interior
Cool to the touch door
Extra-large baking cavity and viewing area
3 Halogen lights for flawless visibility
Gross capacity 5.7 cu. ft.
2 chromed racks
Enameled Broiler Pan

OVEN FUNCTIONS

Bake
Broil
Convection Roast
Convection Broil
Convection Bake
Defrost
Electronic cooking programmer
Self-Clean
Sabbath Mode

ACCENTO

36" DUAL FUEL PROFESSIONAL RANGE

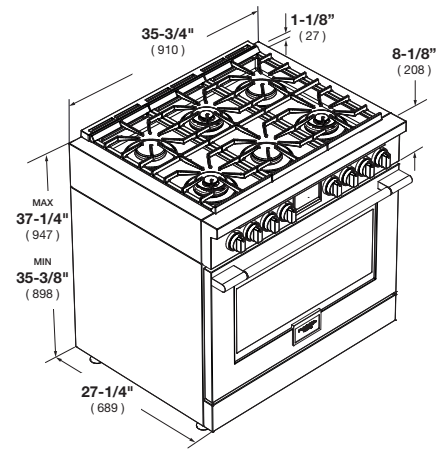

CODE ID		F4PDF366S1 - 36" DUAL FUEL PROFESSIONAL RANGE	
Series and Finish		400 Series - Professional Design - Stainless Steel	
CONTROL PANEL			
Control Type		Electronic	
Display: Clock - Temperature - Function		White LED	
COOKTOP			
Cooking Surface		Black Enameled	
Type		GAS (NG or LP)	
GAS COOKTOP FEATURES			
Electric Flame Ignition and Re-ignition		L.P. Conversion Kit	Top Mount Injectors
Flame-out sensing		Dual Crown Burner	Pressure Regulator
Cooking Zones		6	
Burners types		Dual Flame and Rapid Burners	
Power Front L+R (Max/Min)	G20 - 5" (NG)	18000 (BTU/h) - 5300W / 750 (BTU/h) - 220W	
Power Rear L+R (Max/Min)	G20 - 5" (NG)	15000 (BTU/h) - 4400W / 2200 (BTU/h) - 645W	
Power Front Middle (Max/Min)	G20 - 5" (NG)	15000 (BTU/h) - 4400W / 2200 (BTU/h) - 645W	
Power Rear Middle (Max/Min)	G20 - 5" (NG)	18000 (BTU/h) - 5300W / 750 (BTU/h) - 220W	
Power Front L+R (Max/Min)	G31 - 10" (LP)	15000 (BTU/h) - 4400W / 750 (BTU/h) - 220W	
Power Rear L+R (Max/Min)	G31 - 10" (LP)	12000 (BTU/h) - 3500W / 2200 (BTU/h) - 645W	
Power Front Middle (Max/Min)	G31 - 10" (LP)	12000 (BTU/h) - 3500W / 2200 (BTU/h) - 645W	
Power Rear Middle (Max/Min)	G31 - 10" (LP)	15000 (BTU/h) - 4400W / 750 (BTU/h) - 220W	
OVEN			
Oven Type		Electric Pyro	
Temperature Regulation		Multifunction 2 Fans (True Euro Conv.)	
Temperature Regulation		Electronic	
OVEN FUNCTIONS			
Pyrolytic Self-Clean with automatic door latch		Oven Lights	Broil
True European Convection Bake (Multi level)		Bake	Convection Broil
Convection Roast		Thaw (Defrost)	
ELECTRIC OVEN FEATURES			
Hour Clock Formats AM / PM		Preheat Indicator (25%, 50%, 75%, 100%)	
°C/°F Degree unit		Sabbath Mode	
OVEN DOOR(S)			
Oven Glass Window		Deep Embossed Window	
Door Cooling System		4 Pane Heat Resistant Glasses	
Door Hinges		Heavy Duty Steady Tilt	
Handle Style		Stainless Steel Tube d30mm with Metal terminals	
OVEN CAVITY			
Gross Capacity (cbft)		5.7	
Cavity Enamel Colour		Black	
Rack Positions		6	
Oven Lights		3x20W Halogen	
HEATING ELEMENTS (@240V)			
Broil Upper Heating Element		3100 W	
Upper Auxiliary Element Wattage		1032 W	
Concealed Bake Lower Heating Element		1400 W + 600 W	
Convection Element		2 x 1300 W	
OVEN ACCESSORIES			
Chromed Racks		2	
Enameled Grill set (basin + anti splash)		1	
Telescopic Chromed Rack		Only as optional ACCESSORY	
Meat Probe		Only as optional ACCESSORY	
DIMENSIONS/WEIGHT			
Overall dim - Width		35 - 3/4"	(910 mm)
Overall dim - Height		39"	(993 mm)
Overall dim - Depth		29 - 3/4"	(756 mm)
Gross Weight		344 lbs	(156 kg)
POWER / RATINGS (208/240 V, 60 HZ)			
kW / Amps rating at 120-240V, 60Hz		3.83 kW - 16.5 A	
kW / Amps rating at 120-208V, 60Hz		3.68 kW - 18.2 A	
Power Cable		Nema 14-50P	
INSTRUCTIONS FOR USE			
Use & Care Manual / Installation Manual		English / French / Spanish	