

FORNI MULTIFUNZIONE

FCO 6213 TM X



Acciaio Inox
Anti-impronta



Smalto
Senza Nickel



Cottura
Multi Livello



Sonda
Misurazione
Temperatura



Cucina
Automatica



Porta Sicura



BOOST
Raggiungimento
Rapido Temperatura



Guide
Telescopiche
2 Livelli



Soft
Closing



CLEAN
Programmi
Pulizia Automatici



Classe di
Efficienza
Energetica

FORNO MULTIFUNZIONE ELETTRONICO

Sistema operativo CREATIVE
Classe energetica A++
Soft Closing
Estetica: acciaio inox anti-impronta

PRESTAZIONI

15 funzioni
Cottura automatica
con ricettario pre-selezionato
e modificabile (peso,
temperatura, tempo di cottura)
BOOST per il raggiungimento rapido
della temperatura prescelta
CLEAN, ciclo di pulizia assistita

CARATTERISTICHE

Cruschetto con comandi touch
Vano cottura con Smalto Pyro-grey
(nickel free)
Copriventola in acciaio
Illuminazione interna
Capacità interna 65 litri

SICUREZZA

Porta sicura (4 vetri ipotermici)
Porta con chiusura assistita
Ventilazione tangenziale
di raffreddamento

ACCESSORI DI SERIE

Sonda termica per la rilevazione
della temperatura nei cibi
2 vassoi in vetro temprato
2 griglie metalliche piane
2 set guide telescopiche
ad estrazione totale
Cavo di collegamento con spina

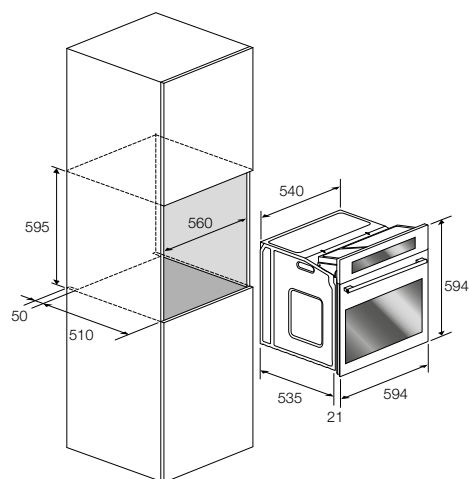

Acciaio inox anti-impronta
FCO 6213 TM X
Cod. EAN 8019801017331