

FORNI PIROLITICI

FQO 6010 P MT X



Acciaio Inox
Anti-impronta



Smalto
Senza Nickel



Digit
Control



Timer



Cottura
Multi Livello



Sistema
Autopulente
per PIROLISI



Porta Fredda
< 50°C



Guide
Telescopiche
1 Livello



Classe di
Efficienza
Energetica

FORNO MULTIFUNZIONE ELETTRONICO

Autopulente

Classe energetica A+

Estetica: Acciaio inox anti-impronta

PRESTAZIONI

10 funzioni

Autopulente per PIROLISI

CARATTERISTICHE

Digit Control e manopole

Vano cottura con Smalto Pyro-grey (nickel free)

Illuminazione interna

Capacità interna 65 litri

SICUREZZA

Porta fredda (<50°C) con 4 vetri

Porta forno con blocco automatico

di sicurezza durante il ciclo autopulente

Cruscotto comandi con blocco di sicurezza

Ventilazione tangenziale di raffreddamento

Catalizzatore per i fumi

ACCESSORI DI SERIE

1 vassoio smaltato Pyro-grey (nickel free)

1 set guida telescopica ad estrazione totale

2 griglie metalliche piane

Cavo di collegamento

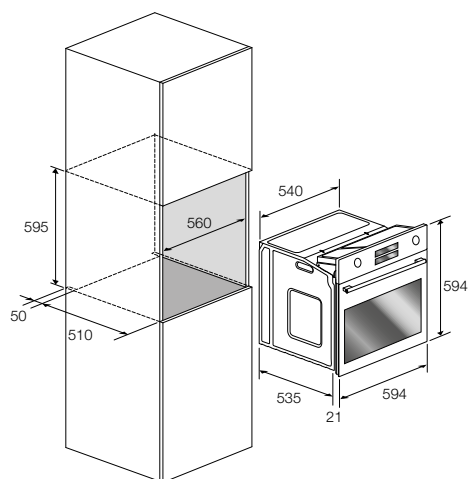

Acciaio inox anti-impronta

FQO 6010 P MT X

Cod. EAN 8019801017096