

SPECIAL

## FVSD 2900 TC



Digit Control



Fingerprint proof stainless steel



Internal Capacity: 8 litres



Glass Cover

### VACUUM SEALING DRAWER WITH OUTER CASE

#### PERFORMANCES

Increasing conservation period of different type of foods  
 Vacuum cycle for preservation (with bags)  
 Vacuum cycle for cooking (with bags)  
 Vacuum cycle for jars – short  
 Vacuum cycle for jars – long  
 Vacuum cycle for containers outside of the chamber

#### FEATURES

Touch control panel  
 Sealing bar  
 Vacuum chamber  
 Tempered glass lid  
 Energy saving function

#### SAFETY

Maintenance cycle:  
 Automatic dehumidifying cycle of the pump oil (20 min)

### ACCESSORIES

Bags for preservation (PA/PE)  
 Bags for cooking (OPA/PP) ,  
 100°C max temperature

### ACCESSORIES ON DEMAND

F 29 X front panel and handle in stainless steel  
 Request the most suitable vacuum jars from your regular dealer  
 Suction Device (for container outside the chamber)

### COMBINATION OPTIONS

With all 60 and 45 cm ovens

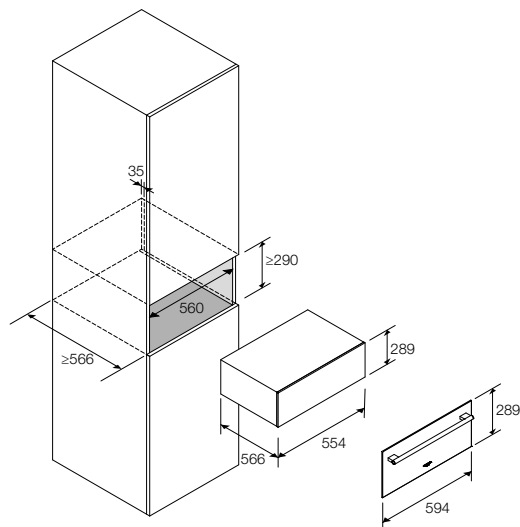

FVSD 2900 TC



Fingerprint resistant stainless steel  
 F 29 X