

30" OVEN 400 SERIES



CODE ID

OVEN 400 SERIES

F4SP30S3



-  True Convection
-  Self Clean Oven
-  Multi-level cooking
-  Cool Touch Door
-  Interior Lighting
-  Digital Controls

SPECIFICATIONS

OVEN

Knob and electronic controls
Single fan true convection
Self-cleaning oven with Multifunction baking
Black Porcelain enamel interior
Cool to the touch
Extra-large baking cavity and viewing area
3 Halogen lights for flawless visibility
Gross capacity 4.4 cu. ft.
2 chrome racks
Enameled Broiler Pan

OVEN FUNCTIONS

Bake
Broil
Roast
Convection
True Convection
Dehydrate
Electronic cooking programmer
Self-Clean
Sabbath Mode

OPTIONAL ACCESSORIES

FMTR630 30" Telescopic Rack

DISTINTO

OVEN 400

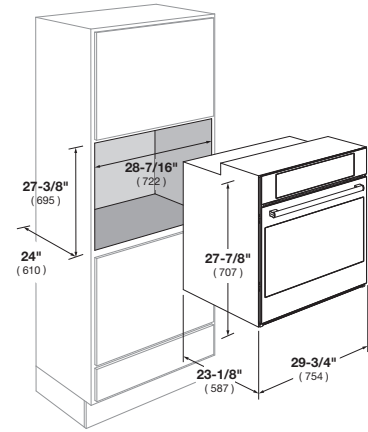

CODE ID	30" OVEN 400 F4SP30S3	
Series	400	
Finish	Stainless Steel	
CONTROL PANEL		
Control Type	Electronic	
Display: Clock - Temperature - Timer	White LED	
Language	English	
OVEN		
Type	True Convection	
Temperature Regulation	Electronic Control (min/max 120/485°F - 50/250°C)	
OVEN FUNCTIONS		
	Pyrolytic Self-Clean	Bake
	True Convection	Broil
	Convection Bake	Thaw (Defrost)
	Convection Broil	Oven Lights
	Convection Roast	
ELECTRIC OVEN FEATURES	Temperature Display °C/°F	
OVEN DOOR(S)		
Oven Glass Window	Large See Through Glass	
Door Cooling System	4 Heat Resistant Glasses	
Door Hinges	Heavy Duty Steady Tilt	
OVEN CAVITY		
Gross Capacity (cbft)	4.4	
Usable Capacity (cbft)	4.1	
Cavity Enamel Color	Black	
Rack Positions	6	
Oven Lights	3x20W Halogen	
HEATING ELEMENTS (@240V)		
Broil Upper Heating Element	3100 W	
Upper Auxiliary Element	1032 W	
Lower Auxiliary Element	600 W	
Concealed Bake Lower Heating Element	1400 W	
Convection Element	2500 W	
OVEN ACCESSORIES		
Chrome Racks	2	
Enameled Broiler Pan (basin + anti splash)	1	
Telescopic Chrome Rack	Optional	
DIMENSIONS/WEIGHT		
Overall dim - Width	29 - 11/16"	754 mm
Overall dim - Height	27 - 7/8"	707 mm
Overall dim - Depth	24"	610 mm
Cut-out - Width	28 - 7/16"	722 mm
Cut-out - Height (min)	27 - 1/4"	692 mm
Cut-out - Depth (min)	23 - 1/4"	590 mm
Gross Weight	181 lbs	82 kg
POWER / RATINGS (208/240 V, 60 HZ)		
kW / Amps rating at 120-240V, 60Hz	3.70kW - 16.1A	
kW / Amps rating at 120-208V, 60Hz	3.49kW - 17.1A	
Power Cable	Conduit	
INSTRUCTIONS FOR USE		
Use & Care Manual / Installation Manual	English / French / Spanish	