











-  Auto - Power Off
-  A+ Energy Class
-  Suction
-  Touch Control
-  Timer
-  Timer Automatic Off
-  LED Lighting
-  Wall - Hung Installation

## WALL HOOD

Energy Class: A+  
Obsidian black glass

## PERFORMANCE

Automatic opening of filtering surface  
Suction power up to 800 m<sup>3</sup> / h  
4 suction levels  
Auto-off  
Filter saturation indicator  
Suction operation with  
filter predisposition  
Sound power from 49 to 71 dBA

## FEATURES

Touch controls  
LED lighting  
Internal aluminium grease filters  
Rated power 275 W  
Minimum air outlet Ø 150 mm  
Non-return air valve (suction)

## SERIES ACCESSORIES

Power Cord

## OPTIONAL ACCESSORIES

FCHF 18: carbon filter for filtering version



OBSIDIAN BLACK GLASS  
FCLHD 900 TC BK

# FULGOR MILANO

## VENTILATION

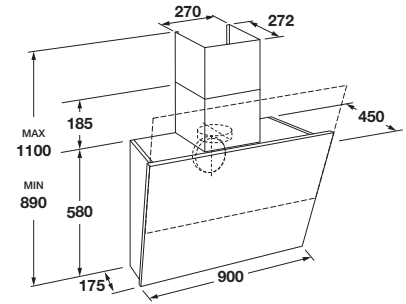

FCLHD 900 TC BK	
Type	Elettronic
Finishing	Obsidian black glass
Installation	Wall
Special feature	Auto Open
<b>FEATURES</b>	
Energy efficiency class	A +
Speed levels	4
Automatic cut-off	•
Grease filter reset warning light	•
Charcoal filter reset warning light	•
Lighting type	LED
Grease filters material	Aluminium
Dishwashable grease filters	•
Ø duct diameter	Ø 150 mm
Non return flap	•
<b>CONTROLS</b>	
Programming non return flap	Touch control
Remote control	-
<b>POWER RATINGS</b>	
Output m <sup>3</sup> /h (max)	757
Sound level (dBA)	49 - 71
Yearly energy consumption (kWh)	46
Motor power (W)	275
Tension and frequency (V-Hz)	230 - 50
Power cord length (m.)	2
<b>ACCESSORIES</b>	
Motor	•
HP filter for filtering version	FCHF 18
<b>DIMENSIONS</b>	
Width mm	900
Height mm	890 - 1100
Depth mm	450