

# CLUSTER CONCEPT COMBISET



CODE ID

VACUUM SEALING DRAWER 15

**FCLVSD 150 TC BK**



Telescopic Rack



Touch Control



Push Opening



## VACUUM SEALING DRAWER

Obsidian black glass  
Push-To-Open system

## PERFORMANCE

CHEF Function  
Increased storage time for individual foods  
Empty cycle for storage (with envelopes)  
Empty cycle for cooking (with bags)  
Empty cycle in the containers - short  
Empty cycle in the containers - long  
Vacuum cycle for jars outside the tank

## FEATURES

Touch control panel  
Welding bar  
Glass lid  
Stainless steel vacuum chamber tank  
Energy saving function

## SAFETY

Pump oil dehumidification  
cycle (20 min)

## INCLUDED ACCESSORIES

Storage bags (in PA / PE) 10 units  
Baking bags (in OPA / PP) 10 units,  
cooking at temp. max. 100 ° C

## OPRTIONAL ACCESSORIES

External vacuum containers  
Suction device (external containers)

## MATCH WITH

Appliances of CLUSTER CONCEPT line



OBSIDIAN BLACK GLASS  
FCLVSD 150 TC BK

# CLUSTER CONCEPT

VACUUM DRAWER

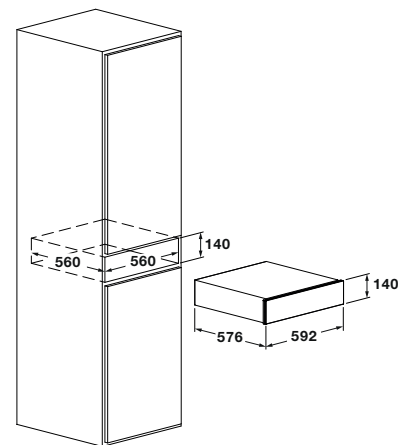

FCLVSD 150 TC BK	
Type	Vacuum sealing drawer
Finishing	Obsidian black glass
Inner sleeve	Stainless Steel
FEATURES	
Opening type	Push to Open
Programming	Touch key
Functions	4
Max vacuum level	2-10 mbar( 99,9%)
Usable inner capacity (liters)	7 L
Chamber height	95 mm
Lid opening	65°
Removable sealing bar length	260 mm
CHEF cycle	•
Cooking bag sealing cycle time	55"
Preservation bag sealing cycle time	3/70"
Vacuum in outer container	•
Bags max dimensions in cm	25 x 35
Oil refill warning light	•
Oil dehumidification cycle	•
POWER RATINGS	
Max absorbed power ( W )	230 W
Tension and frequency ( V-Hz )	220 - 240 / 50 - 60
Cord	•
Plug Type	Schuko
DIMENSIONS	
Width mm	592
Height mm	140
Depth mm	576
Cut-out ( W x H x D ) mm	560 x 140 x 560