

# PROFESSIONAL



CODE ID

COMBINED MICROWAVE OVEN 30"

**FPCMO 300 TEM X**



Creative



Microwave Cooking



Thawing



True Convection



Automatic Cooking



Cool Touch Door



Multi-Level Cooking

## PROFESSIONAL 30" COMBINED MICROWAVE OVEN

Finishing: Professional stainless steel

### PERFORMANCE

10 combined functions  
Automatic cooking  
Preselected and customizable recipes  
(weight and cooking time)  
Microwave mode (6 levels)  
Assisted ventilation mode  
Combined cooking mode  
Microwave and grill mode  
Thawing by time and weight

### FEATURES

Microwave, convection and combined  
Interior in stainless steel  
Quick access menu  
Automatic programs

### INCLUDED ACCESSORIES

Chromed grid  
Stainless steel tray



STAINLESS STEEL  
FPCMO 300 TEM X

# PROFESSIONAL

## COMBINED MICROWAVE OVEN

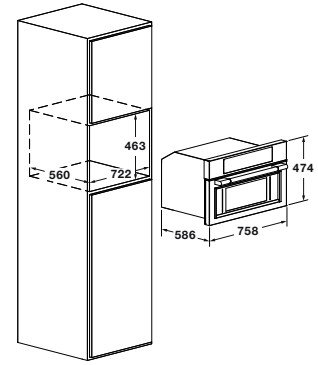

<b>FPCMO 300 TEM X</b>	
Type	Combined Microwave
Finishing	Stainless steel
Temperature regulation	Electronic
<b>FUNCTION</b>	
Microwave / steam cooking	•/-
Steam heating	-
Microwave / steam convection	•
Steam / circuit cleaning	-
5 minutes steam	-
Convection cooking	-
Convection roast	•
Convection grilling	•
Cooking on the grill	•
Eco convection cooking	-
Recipes	•
Oven lights	•
<b>COMMANDS</b>	
Type of control	Creactive Extended
Display	TFT 3.5"
Recipes menu	•
Commands	Double Full Touch keyboard
Languages	7
<b>FEATURES</b>	
Quick manual preheating	-
Probe	-
12/24 clock format	•
° C / ° F	•
<b>OVEN DOOR</b>	
Cold door	•
<b>OVEN CAPACITY</b>	
Gross capacity (liters)	34 L
Interior: enamel	Stainless steel
Position of grids	3
Lighting (Halogen 20 W) n.	1
Upper heating element for grilling	1500 W (230 V)
Steam generator	-
Lower element power	-
Convection element power	1500 W (230 V)
<b>ACCESSORIES</b>	
Flat grids / Telescopic n.	1 / -
Stainless steel tray	•
<b>POWER RATING</b>	
Max oven electric power (W)	3200 W
Voltage / Frequency (V - Hz)	220 - 40 / 50
Power cable / Plug	• / Schuko
<b>DIMENSIONS</b>	
Width mm	758
Height mm	474
Depth mm	586
Cut-out ( W x H x D ) mm	722 x 463 x 560