



Creative



Steam Cooking



Steam Limescale Filter



True Convection



Automatic Cooking



Cool Touch Door



Multi-Level Cooking



Meat Probe

PROFESSIONAL 30" COMBINED STEAM OVEN

Finishing: Professional stainless steel

PERFORMANCE

12 functions
Automatic cooking
Preselected and customizable recipes
(weight and cooking time)
Combined cooking functions
Steam recovery cycle
CLEAN, assisted cleaning cycle for
inside the oven and steam circuit

FEATURES

Steam, convection and combined steam
Interior in stainless steel
Quick access menu
Automatic programs
Steam generator

INCLUDED ACCESSORIES

Meat probe
Chromed grid
Stainless steel tray



STAINLESS STEEL
FPCSO 300 TEM X

PROFESSIONAL

COMBINED STEAM OVEN

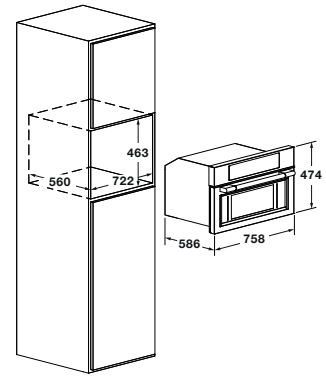

FPCSO 300 TEM X	
Type	Combined Steam
Finishing	Stainless steel
Temperature regulation	Electronic
FUNCTION	
Microwave / steam cooking	-/•
Steam heating	•
Microwave / steam convection	•
Steam / circuit cleaning	•
5 minutes steam	•
Convection cooking	•
Convection roast	•
Convection grilling	•
Cooking on the grill	•
Eco convection cooking	•
Recipes	•
Oven lights	•
COMMANDS	
Type of control	Creactive Extended
Display	TFT 3.5"
Recipes menu	•
Commands	Double Full Touch keyboard
Languages	7
FEATURES	
Quick manual preheating	•
Probe	•
12/24 clock format	•
° C / ° F	•
OVEN DOOR	
Cold door	•
OVEN CAPACITY	
Gross capacity (liters)	34 L
Interior: enamel	Stainless steel
Position of grids	3
Lighting (Halogen 20 W) n.	1
Upper heating element for grilling	1500 W (230 V)
Steam generator	800 W (230 V)
Lower element power	300 W (230 V)
Convection element power	1500 W (230 V)
ACCESSORIES	
Flat grids / Telescopic n.	1 / -
Stainless steel tray	•
POWER RATING	
Max oven electric power (W)	3200 W
Voltage / Frequency (V - Hz)	220 - 40 / 50
Power cable / Plug	• / Schuko
DIMENSIONS	
Width mm	758
Height mm	474
Depth mm	586
Cut-out (W x H x D) mm	722 x 463 x 560