



Autospegnimento



Classe di Efficienza Energetica



Filtrante



Touch Control



Timer



Telecomando



Filtrante



Illuminazione LED



Downdraft

CAPPA CON SISTEMA LIFT-UP

Classe energetica A

PRESTAZIONI

Apertura dinamica
 Capacità di aspirazione fino a
 760 m³ / h con 4 livelli intermedi
 Auto spegnimento
 Spia saturazione filtri
 Emissioni sonore da 38 a 68 dBA

CARATTERISTICHE

Comandi touch e telecomando Illuminazione
 a LED
 Filtri anti-grasso con recupero olio Diametro
 minimo collegamento scarico Ø 150 mm
 Flap di non ritorno del flusso di aria

ACCESSORI DI SERIE

Cavo alimentazione (2 m)

ACCESSORI SU RICHIESTAFCHF 9: Filtro HP (x 2) per conversione a
filtrante

VETRO NERO LUCIDO

FDDH 900 TRC BK

FULGOR MILANO

DOWNDRAFT

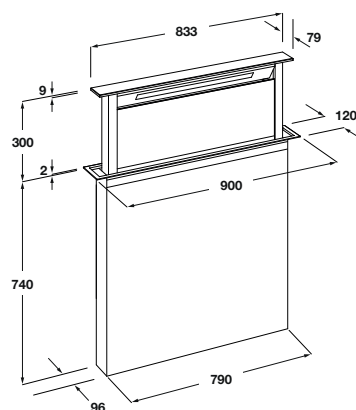

FDDH 900 TRC BK	
Tipologia	Downdraft
Estetica	Vetro nero
Installazione	Sopra top
Caratteristica speciale	Lift
CARATTERISTICHE	
Classe di efficienza energetica	A
Livelli di aspirazione	4
Autospegnimento	-
Spia saturazione filtri antigrasso	-
Spia saturazione filtri HP	-
Illuminazione	Strip LED
Tipo filtri antigrasso	Alluminio
Filtri antigrasso lavabili in lavastoviglie	•
Ø scarico minimo uscita aria	Ø 150 mm / rett. 220 x 90 (230 x 80)
FLAP di non ritorno del flusso d'aria	•
COMANDI	
Programmazione	Touch control
Telecomando	•
PRESTAZIONI / DATI ELETTRICI	
Potenza aspirazione m ³ /h (max)	757
Rumorosità (dBA)	42 - 59
Consumo annuo (kWh)	45
Potenza motore (W)	275
Tensione / Frequenza (V - Hz)	220 - 240 / 50 - 60
Cavo di alimentazione (m)	2
ACCESSORI	
Motore incluso	-
Filtro HP per versione filtrante	FCHF 9 (x 2)
DIMENSIONI	
Larghezza mm	900
Altezza mm	300
Profondità mm	79