

# REFRIGERATION









CODE ID

BUILT-IN COMBINED REFRIGERATOR

**FBCD 761 TNF EDBL**



-  Digital Touch Display
-  LED Lighting
-  Total No Frost
-  Mounting Self-Supporting Hinges
-  Reversible Door
-  Quick Freezing
-  Integrated

## COMBINED REFRIGERATOR 30"

Energy class E

### PERFORMANCE

Total gross capacity 460 litres  
Fast Freezing function  
Holiday function  
Automatic defrosting  
Climatic class SN-T

### FEATURES

Digital touch display  
LED interior lighting  
Fresh water dispenser  
Automatic ice maker  
No Frost cooling system  
3 Glass shelves  
2 Removable drawers  
2 Fruit and vegetable drawers  
3 Balconies in the counter door  
Eggs rack  
Reversible door  
Self supporting hinges

## SECURITY

Door open buzzer system  
Temperature indicator  
Quick-freeze indicator



COMBINED REFRIGERATOR  
FBCD 761 TNF EDBL

# REFRIGERATION

## BUILT-IN COMBINED REFRIGERATOR

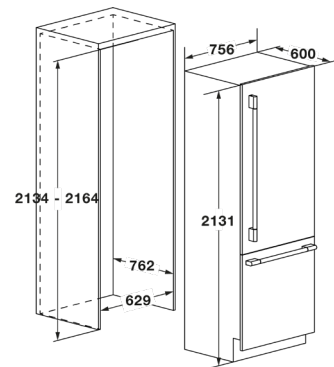

FBCD 761 TNF EDBL	
Type	Bottom Mounted
Installation	Built-in
Door fixing	Door on Door
Reversible hinging	•
<b>PERFORMANCE</b>	
Total gross volume	460 L
Total net volume	452 L
Energy efficiency class	E
Energy consumption (KWh / year) based on standard 24 hour test results *	551
Max autonomy without electricity (h)	11
Freezing capacity (Kg / 24h)	5,8
Climatic class	SN-T
Sound level dB (A) re1pW	43
<b>GENERAL FEATURES</b>	
Electronic control	•
Digital display	•
Independent Fridge / Freezer temperature regulation	•
Holiday function	•
Door open alarm	•
Temperature indicator	•
Super freeze indicator	•
Lighting	LED
No. compressors / type	1/Inverter
Refrigerant gas	R600a
<b>FRIDGE COMPARTMENT</b>	
Cooling system	No Frost
Defrost	Automatic
Side led lights	•
Fresh zone 0°C	•
Water dispenser	•
Glass shelves	3
Egg container	•
Fruit and vegetable drawers	•
Net fridge volume	325 L
<b>FREEZER COMPARTMENT</b>	
Cooling system	No Frost
Defrost	Automatic
Fast freezing	•
Extractable drawers	2
Automatic Ice Maker	•
Net freezer volume	127 L
<b>ELECTRICAL FEATURES</b>	
Max power input at 220 V	572W
Power supply (V / Hz)	220-240 / 50-60
Schuko plug	•
<b>WEIGHT, DIMENSIONS</b>	
Weight kg	155
Height mm	2123
Width mm	756
Depth mm	595