



Combined Refrigerator 60

FBCD 355 TNF EDBL



- Built-in installation
- Total No Frost cooling
- Digital display
- Total gross capacity: 252 litres
- Fast Freezing Function
- Holiday function
- Automatic defrosting
- Interior LED lighting
- Self-supporting hinges
- Reversible doors
- Energy Class: E (ex A++)

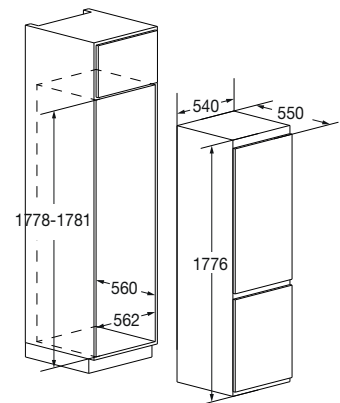

Features

TOTAL NO FROST combined refrigerator featuring a large backlit rear panel for a unique design. Besides the Produce drawer, the appliance features a Fresh drawer for meat and fish (+ -3 °C). This refrigerator also has four glass shelves and three balconies on the counterdoor with an egg rack. The TOTAL NO FROST freezer features three large removable drawers. Independent temperature regulation between the refrigerator and freezer. Moreover, it comes with an open-door buzzer, a temperature indicator and a quick freezer indicator.



COMBINED REFRIGERATOR
FBCD 355 TNF EDBL
EAN 8019801030538

REFRIGERATION

REFRIGERATORS



FBCD 355 TNF EDBL	
Type	Combined
Finish	Built-In
Fixing	Self-supporting hinges
Reversible doors	•
PERFORMANCE	
Total gross capacity	252 L
Total net capacity	237 L
Efficiency class	E
Energy consumption (KWh / year) based on results of standard testing over 24 hours*	235
Autonomy without electricity (h)	11
Freezing power (Kg / 24h)	2.6
Climate class	SN-T
Sound level dB (A) re1pW	41
GENERAL FEATURES	
Electronic regulation	•
Digital display	•
Independent regulation Refrigerator / Freezer temperature	•
Holiday function	•
Open door buzzer	•
Temperature indicator	•
Fast Freezing indicator	•
Lighting	LED
No. of compressors / type	1/Inverter
Refrigerant gas	R600a
REFRIGERATOR COMPARTMENT	
Cooling system	No Frost
Defrosting	Automatic
Rear panel with LED light	•
"FRESH 0 °C" zone	•
Glass shelves	4
Egg container	•
Produce drawer	•
Refrigerator compartment volume	170 L
FREEZER COMPARTMENT	
Cooling system	No Frost
Defrosting	Automatic
Fast Freezing / Removable drawers	• / 3
Freezer compartment volume	67 L
POWER RATING	
Max power absorbed at 220 V	176W
Power supply (V - Hz)	220-240 / 50-60
Plug (Schuko)	•
WEIGHT, DIMENSIONS	
Weight (kg)	60
Dim. Product (W x H x D) mm	177 x 540 x 550
Built-In Cut Out (HxWxD)	1775x560x560