



Integrated hood 80

FBGHD 800 PT X



- Soft touch controls
- White satin-finish glass finish
- Extraction output: 700 m³/h
- 4 suction levels
- Power off timer
- LED bar lighting
- Aluminium anti-grease filters
- Filter saturation indicator
- Non-return valve
- Sound power from 47 to 70 dBA
- Energy Class A

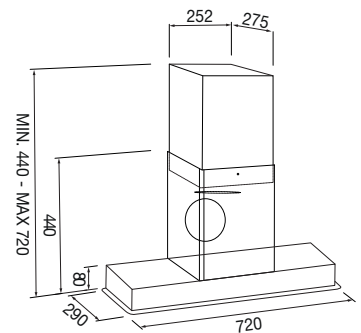

Features

Built-In hood. With satin-finish glass perimetral extraction. (air is extracted along the centre panel's perimeter). The LED bar illuminates the hob optimally, the upper and functional elements are integrated inside the wall unit but easy to access for maintenance purposes. The anti-grease filters are dishwasher-safe.

Accessories on request:

- HP activated carbon filter - filtering version use

FCHF 13



STAINLESS STEEL
FBGHD 800 PT X
EAN 8019801023158

EXTRACTION

INSERTION HOODS



FBGHD 800 PT X	
Type	Integrated
Finish	Stainless steel
Installation	In wall unit
FEATURES	
Efficiency class	A
Extraction levels	4
Timer and auto power off	•
Anti-grease filter saturation indicator	•
HP filter saturation indicator (filtering)	•
Lighting	LED bar
Type of anti-grease filters	Aluminium
Dishwasher-safe anti-grease filters	•
Minimum air outlet tube \varnothing	\varnothing 150 mm / rect.
Airflow non-return valve	•
CONTROLS	
Operating system	Soft touch
PERFORMANCE / ELECTRICAL DATA	
Extraction power m ³ /h (max)	700
Noise (dBA)	47 - 70
Annual consumption (kWH)	50
Motor power (W)	275
Voltage / Frequency (V - Hz)	230 - 50
Power cord (m)	2
Plug (Schuko)	•
ACCESSORIES	
Motor included	•
HP filter for filtering version (on request)	FCHF 13
DIMENSIONS	
Width (mm)	780
Height (mm)	440
Depth (mm)	290