



Integrated hood 85

FBGHD 850 TC X



- Touch controls
- Stainless steel finish
- Extraction output: 780 m³/h
- 4 suction levels
- Power off timer
- LED bar lighting
- Aluminium anti-grease filters
- Filter saturation indicator
- Non-return valve
- Sound power from 45 to 71 dBA
- Energy Class A+

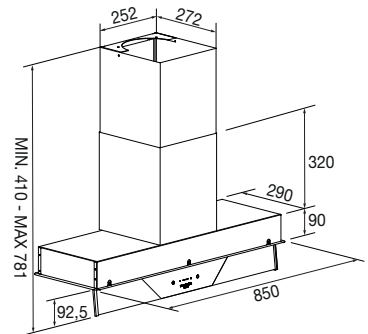

Features

Hood to be installed into a cabinet with retractable clear glass visor including touch controls.. The LED bar illuminates the hob optimally, the upper and functional elements are integrated inside the wall unit but easy to access for maintenance purposes. The anti-grease filters are dishwasher-safe.

Accessories on request:

- HP activated carbon filter - filtering version use

FCHF 8



STAINLESS STEEL
FBGHD 850 TC X
 EAN 8019801023042

EXTRACTION

INSERTION HOODS



FBGHD 850 TC X	
Type	Integrated
Finish	Stainless steel
Installation	Under cabinet
FEATURES	
Efficiency class	A +
Extraction levels	4
Timer and auto power off	•
Anti-grease filter saturation indicator	•
HP filter saturation indicator (filtering)	•
Lighting	LED
Type of anti-grease filters	Aluminium
Dishwasher-safe anti-grease filters	•
Minimum air outlet tube \varnothing	\varnothing 150 mm / rect.
Airflow non-return valve	•
CONTROLS	
Operating system	Touch control
PERFORMANCE / ELECTRICAL DATA	
Extraction power m ³ /h (max)	780
Noise (dBA)	45 - 71
Annual consumption (kWH)	45
Motor power (W)	275
Voltage / Frequency (V - Hz)	230 - 50
Power cord (m)	2
Plug (Schuko)	•
ACCESSORIES	
Motor included	•
HP filter for filtering version (on request)	FCHF 8 (X2)
DIMENSIONS	
Width (mm)	850
Height (mm)	350
Depth (mm)	290