



## 30" coffee machine

FCM 4500 TF BK + F6PTK30BC



- Deep Black finish
- 30 functions
- TFT touch control display
- Automatic programs
- Coffee bean container (200 g)
- Integrated and adjustable grinding
- Milk container
- Water container (1.8 l)
- Removable hot water dispenser
- Liquid collection container
- Five types of cup

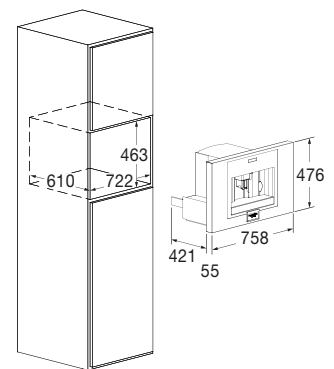

## Features

The integrated coffee machine can be considered a personal barista. It allows the conservation of coffee beans, their instant grinding and the automatic storage of the grounds in the collection tray. Coffee like at the coffeeshop, with the possibility, with the simple touch of a button, of choosing 5 different coffee variations, passing from espresso to cappuccino. This professional quality machine, easy to use and made in Italy, is the perfect complement to your Fulgor Milano kitchen products. The exclusive PRO FRAME KIT (optional) allows perfect combination with the other built-in appliances of the Professional 30" series. The touch control and the digital display make the use of the coffee machine intuitive and immediate. There is the possibility of choose coffee quantity and intensity, from very light to extra strong. In addition to this, numerous drinks can be prepared thanks to the automatic cappuccino maker and the hot water dispensing for tea and herbal teas. For an optimal result, it is also possible to verify the water hardness. The system is equipped with stand-by to save electricity and an extensive safety system: light indicator for no water, no coffee, need for a cleaning cycle and replacement of the limescale filter. Access to the service compartments is through a practical opening. The badge with the Fulgor Milano logo can optionally be positioned as desired by the customer.



BLACK GLASS  
FCM 4500 TF BK  
EAN 8019801025077



PRO FRAME KIT  
F6PTK30BC  
EAN 8019801026265

# PROFESSIONAL

COFFEE MACHINE 45



FCM 4500 TF BK + F6PTK30BC	
Type	Coffee machine
<b>PERFORMANCE</b>	
Total functions no. / Operating system	30 / Full Touch TFT
Automatic functions	Coffee, steam, hot water
Energy efficiency	A
Annual energy consumption (kWh)	45
Water / coffee container capacity	1.8 L / 200 g
Coffee grinder with 13 regulation levels	•
Coffee cups no.	2
	Height-adjustable (80-100 mm) coffee dispenser
	Retractable dispenser for steam and hot water
	Compartment LED lighting
	Automatic descaling program
Integrated cleaning program	•
Milk container (0.75 l)	•
Drip tray	•
Anti-scale filter indicator / water reserve indicator	• / •
Residual emptying indicator	•
Telescopic rails	•
<b>POWER RATING</b>	
Max electrical power (W)	1350 W
Voltage / Frequency (V - Hz)	220 - 240 V; 50 - 60 Hz
Power cord / Plug	• / Schuko
Pump pressure (bar)	15
<b>DIMENSIONS</b>	
Product (W x H x D) mm	594 x 455 x 443
Built-In Cut Out (W x H x D) mm	560 x 450 x 560
Professional Product (W x H x D) mm	758 x 476 x 476
Pro Built-In Cut Out (W x H x D) mm	722 x 463 x 610