



## Lift Hood 90

FDDH 900 TRC BK



- Touch controls and remote control
- Electric opening/closing device
- Black Glass finish
- Power off timer
- LED bar lighting
- Aluminium anti-grease filters
- Filter saturation indicator
- Oil drip tray
- Non-return valve
- Energy Class A

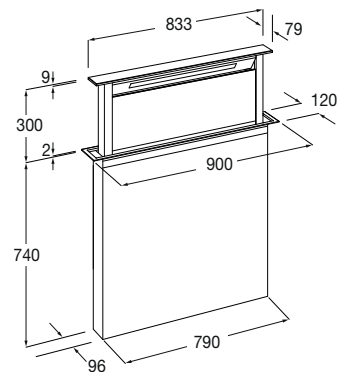

## Features

Rear lift hood. **Motors to be ordered separately.** With an FDD 2M motor, the extraction output is 760 m<sup>3</sup>/h (4 power levels). The sound power varies depending on the motor installed.

Accessories on request:

- On-Board motor
- Inner remote motor
- Outer remote motor
- Activated carbon filter - filtering version use

FDD 2M  
FEM 1  
FEM 2  
FCHF 9



BLACK GLASS  
FDDH 900 TRC BK  
EAN 8019801022311

# EXTRACTION

## DOWNDRAFT (LIFT) HOODS



FDDH 900 TRC BK	
Type	Downdraft
Finish	Black Glass
Installation	On the countertop
<b>FEATURES</b>	
Efficiency class	A
Extraction levels	4
Auto power off	•
Anti-grease filter saturation indicator	•
Carbon filter saturation indicator (filtering)	•
Lighting	LED bar
Type of anti-grease filters	Aluminium
Dishwasher-safe anti-grease filters	•
Minimum air outlet tube $\varnothing$	$\varnothing$ 150 mm / rect. 220 x 90 x (230 x 80)
Airflow non-return valve	•
<b>CONTROLS</b>	
Operating system / Remote control	Touch control / •
<b>PERFORMANCE / ELECTRICAL DATA</b>	
Suction power m <sup>3</sup> /h (max) with FDD2M / FEM1 / FEM2	760 - 680 / 730
Noise (dBA) with FDD2M / FEM1 / FEM2 min.- max	38 - 68 / 28-59 / 43 - 62
Annual consumption (kWh) FDD2M / FEM1 / FEM2	44.5 / 58.5 / 87
Motor power (W) FDD2M / FEM1 / FEM2	275 / 275 / 200
Voltage / Frequency (V-Hz)	230 - 240 / 50 - 60
Power cord (m)	2
<b>ACCESSORIES</b>	
Motor included	-
On-Board motor (on request)	FDD 2M
Internal remote motor (on request)	FEM 1
External remote motor on request	FEM 2
HP filter for filtering version (on request)	FCHF 9
<b>DIMENSIONS</b>	
Width (mm)	790
Height (mm)	min.740 max 1040
Depth (mm)	96 + motor