



Wall-mounted hood 120

FTHD 1200 TC X



- Stainless steel touch controls
- Stainless steel finish
- Extraction output: 730 m³/h
- Extraction power: 5 levels
- Power off timer
- Sound power from 47 to 72 dBA
- LED bar lighting
- Baffle anti-grease filters
- Filter saturation indicator
- Non-return valve
- Energy Class A

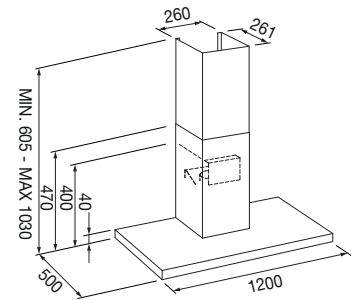

Features

The T-shaped wall-mounted hood's top can be used as a support base for kitchen utensils. It features high-efficiency baffle anti-grease filters. The LED bar ensures optimal illumination of the hob and can be used as a courtesy light. The anti-grease filters are dishwasher-safe.

Accessories on request:

- HP activated carbon filter - filtering version use

FCHF 49



STAINLESS STEEL
FTHD 1200 TC X
EAN 8019801023080

EXTRACTION

WALL-MOUNTED HOODS



FTHD 1200 TC X	
Type	Visible
Finish	Stainless steel
Installation	Wall-mounted
FEATURES	
Efficiency class	A
Extraction levels	5
Auto power off	• 10 minutes
Anti-grease filter saturation indicator	•
HP filter saturation indicator (filtering)	•
Lighting	LED bar
Type of anti-grease filters	PRO stainless steel baffle
Dishwasher-safe anti-grease filters	•
Minimum air outlet tube \varnothing	\varnothing 150 mm / rect.
Airflow non-return valve	•
CONTROLS	
Operating system	Touch control
Remote control	•
PERFORMANCE / ELECTRICAL DATA	
Extraction power m ³ /h (max)	730
Noise (dBA)	47 - 72
Annual consumption (kWh)	49
Motor power (W)	275
Voltage / Frequency (V - Hz)	230 - 50
Power cord (m)	2
Plug (Schuko)	•
ACCESSORIES	
Motor included	•
HP filter for filtering version (on request)	FCHF 49 (X2)
DIMENSIONS	
Width (mm)	1200
Height (mm)	1200
Depth (mm)	500