

24" VETROCERAMIC COOKTOP

CODE ID

700 SERIES

F7RT24S1

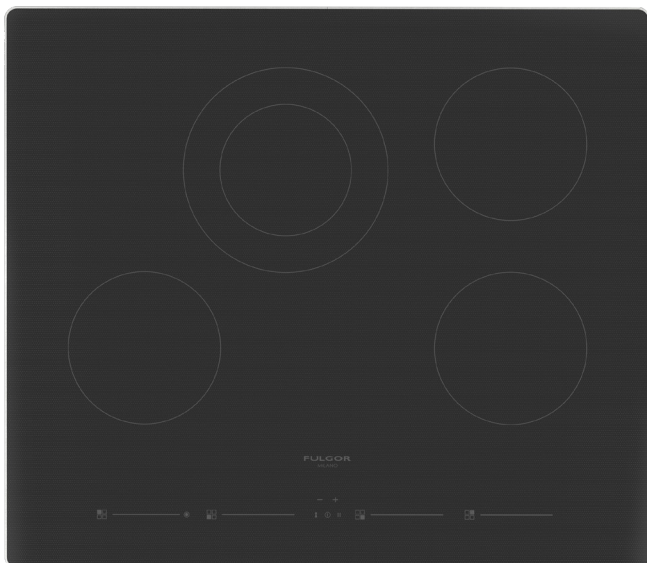

Easy Clean Ceramic Glass



Slide Touch Control



Residual Heat Sensor



Digital Minute Minder

VETROCERAMIC COOKTOP

4 Vetroceramic cooking zones
Slide touch control for power setting
Elegant Ceramic glass surface
Melt Function
Residual heat and Power on Indicators
Digital Minute Minder

Child Lock Function
Independent timer for each zone
Pause function
Failure Codes Indication
Digital Display for Power Level
Automatic Heat-up Time



This product meets ADA (Americans with Disabilities Act) requirements. Please check with your local municipality's codes and stipulations for additional details to ensure compliance.

24" VETROCERAMIC COOKTOP

700 SERIES

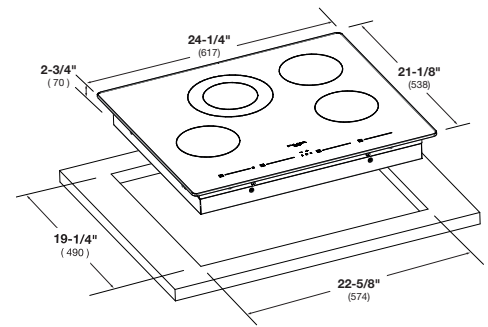

24" BUILT-IN VETROCERAMIC COOKTOP F7RT24S1	
CODE ID	
Size	24"
Colour	Black
Heating Technology	Radiant Heaters
Glass Type	Glass Ceramic + Aluminum Frame
Control type	Touch TC FLEX
CONTROL FEATURES	
Slide touch control for power setting	•
Power levels	1 to 9
Digital display for power level indication (7 segments)	•
Led bar for power level indication	•
Melting Function (Led Indicator)	•
Residual heat indication for each zone (HOT)	•
Minute minder functions for each zone + one general (Led Indicator)	1+4
Key Lock (Led Indicator)	•
Pause/recall (Led Indicator)	•
General ON/OFF Key (Led Indicator)	•
Dedicated ON/OFF Key for each zone	•
Acoustic buzzer	•
SINGLE ZONE 1	Front Right Zone
Size	5" 3/4 (145mm)
Power	1200W
SINGLE ZONE 2	Front Left Zone
Size	5" 3/4 (145mm)
Power	1200W
SINGLE ZONE 3	Rear Left Zone
Size	7-5/8" / 4-7/8" (195/125mm)
Power L9	1900W (1100+800W)
SINGLE ZONE 4	Rear Right Zone
Size	5" 3/4 (145mm)
Power L9	1200W
DIMENSIONS/WEIGHT - (IN OR LBS)	
Overall dim - width	24" 1/4 (617mm)
Overall dim - depth	21" 1/8 (538mm)
Overall dim - height (without Conduit)	3" (75mm)
Cutout - width (min - max)	min. 22-5/8" (574 mm) - max 22 13/16" (580 mm)
Box - height	2 3/4" (70mm)+ conduit 1" 1/8 (30mm)
Cutout - depth (min - max)	min. 19-1/4" (490 mm) - max 19 9/16" (497 mm)
Approx ship weight	28.6lb (13Kg)
POWER / RATINGS (208/240 V, 60 HZ)	
KW/Amps rating at 240V, 60Hz	5.50kW - 22.9 Amps
KW/Amps rating at 208V, 60Hz	4.10kW - 19.7Amps
Cable + Conduit	•
INSTRUCTIONS FOR USE	
Use & Care Manual	EN, SP, FR
Installation Manual	EN, SP, FR