



Pro Multifunction 48"

FSRC 4807 2P MK 2F X



- Electronic multifunction ovens
- Pizza Pizzeria 350 °C function
- AirFry (oven-frying) function
- Pyrolytic self-cleaning ovens
- Fast pre-heat function
- Main oven with dual convection
- Ventilated accessory oven
- Meat Probe
- Cool touch soft-close door
- Creative Digital Control with knobs
- INOX finish reversible plate cover
- Metal knobs with stainless steel finish
- Professional cast iron grates
- Pro Heavy Duty Enamelled Ribbon Plate / Griddle
- Matte black enamelled bowl
- 6 Crescendo Dual Gas Burners
- 1 Teppanyaki tubular burner
- NG or LPG supply

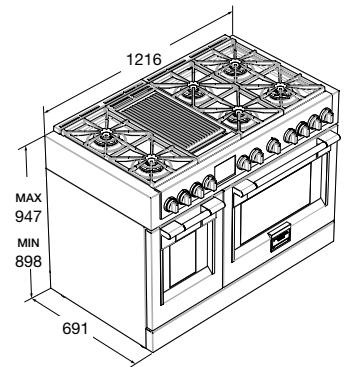

Features

SOFIA PRO 48 DUAL FUEL represents the excellence of FULGOR MILANO, it is synonymous with Italian style, mastery in product development and accuracy in workmanship. Thanks to the cooktop equipped with 6 Crescendo Dual brass gas burners, the reversible griddle featuring grills or TeppanYaki, and the two high-performance pyrolytic multifunction ovens, this version proves to be a flexible tool, capable of enhancing the creative aptitudes of kitchen professionals. The standard accessories of the main oven include a fully extractable telescopic rack, two flat racks, a MEAT probe, pizza set (round rack, peel and pizza stone), enameled tray with anti-splash and tray for AirFry. The support oven has a fully extractable telescopic rack, two flat racks and a stainless-steel tray for AirFry.



STAINLESS STEEL
 FSRC 4807 2P MK 2F X
 EAN 8019801022649

PROFESSIONAL

48" FREE-STANDING KITCHEN



FSRC 4807 2P MK 2F X	
Type	48" free-standing kitchen
Finish	Stainless Steel
Interiors: enamelled / other	Ultra Black Piro / -
COOKING HOB	
Supply	Gas
Tubular griddle burner	1 x 1200 - 3350 W
Crescendo burner power (Min-Max)	2 x 450 - 4500 W / 4 x 450 - 4000 W
Gas safety	•
Cast iron grates / griddle no.	3 / 1
Hob surface	Matte black enamelled
Ovens	
Type	Electronic multifunction
Dual convection / Thermoventilated	Primary / Secondary
Efficiency class	A
Capacity (litres)	125 + 65 L
Forced cooling	•
Functions no.	18
PERFORMANCE	
Max cooking temperature	290° C
Pyrolysis temperature / Self-cleaning	460° C / •
Pizza Pizzeria 350° function	•
AirFry (oven-frying)	•
CONTROLS	
Control system	Creactive with knobs
Recipes	•
Automatic power off	•
Booster	•
Meat probe	Primary oven
SAFETY	
Door lock (during pyrolysis)	•
Cool-touch door / no. of glass panes	• / 4
Soft-close door	•
ACCESSORIES	
Lighting (Halogen, 20 W) no.	3 + 2
Flat racks no.	2 + 2
Telescopic rack no.	1 + 1
Trays no. / type	1 / enamelled tray
Enamelled AirFry tray	1
Stainless steel AirFry tray	1
Round rack / Pizza shovel	1 / •
Firestone for pizza no.	1
POWER RATING / GAS	
Max electrical power (W)	7000 W
Voltage / Frequency (V - Hz)	220 - 240 V / 380 - 415V 2 N ~; 50 - 60 Hz
Gas types	NG - LPG
Cord / Plug	- / -
DIMENSIONS	
Width (mm)	1216
Height (min - max) mm	898 - 947
Depth (mm)	691