

# ACCENTO PROFESSIONAL 30"

30" DUAL FUEL PROFESSIONAL RANGE



CODE ID



**F4PDF304S1**



Heavy Duty Grates



Continuous Grate Surface



Dual Crescendo Burner



Dual True Convection



Self Clean Oven



Multi-level cooking



Cool Touch Door



Digital Controls

## COLOR KIT

	STAINLESS STEEL	
	MATTE BLACK	RAL 9004
	MATTE WHITE	RAL 9016
	GLOSSY RED	RAL 3003

## OPTIONAL ACCESSORIES

ACDKIT30 ...	Color kit
FMWOK	Wok ring
FMSIM	Simmer plate
F6BG30BCI	Island trim
F6BG30STD	Standard trim
F6BG30HBT	High back trim
FMGRID30	Griddle
FMTR630	Telescopic rack
F6BG30ISL	1" Island trim

## COOKING SURFACE

2 Heavy Duty, continuous cast iron grates  
One piece, matte finish porcelain burner bowl  
2 Dual-Flame Crescendo Burners  
2 X 18,000 BTU max (NG)  
2 Rapid Burners  
2 X 15,000 BTU max (NG)  
Natural Gas (LP convertible)

## OVEN

Dual True Convection  
Self-cleaning oven with Multifunction baking  
Black Porcelain enamel interior  
Cool to the touch door  
Extra-large baking cavity and viewing area  
3 Halogen lights for flawless visibility  
Total capacity 123 lt  
Total capacity 4.4 cu. ft.  
2 chrome racks  
Enameled Broiler Pan

## OVEN FUNCTIONS

Bake  
Broil  
Roast  
Convection  
True Convection  
Dehydrate  
Electronic cooking programmer  
Self-Clean  
Sabbath Mode

# ACCENTO

30" DUAL FUEL RANGE

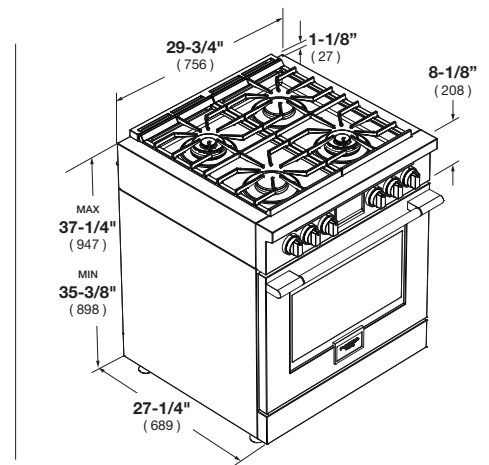

CODE ID		F4PDF304S1 - 30" DUAL FUEL PROFESSIONAL RANGE		
Series and Finish		400 Series - Professional Design - Stainless Steel		
<b>CONTROL PANEL</b>				
Control Type		6 Heavy Duty Knobs		
Display: Clock - Temperature - Function		White LED		
<b>COOKTOP</b>				
Cooking Surface		Black Enameled		
Type		GAS (NG or LP)		
<b>GAS COOKTOP FEATURES</b>				
		Electric Flame Ignition and Re-ignition	L.P. Conversion Kit	Top Mount Injectors
		Flame-out sensing	Dual Crown Aluminum Burner	Pressure Regulator
Cooking Zones		4		
Burners Type		Rapid Burner		
Power Front-L, Rear-R (Max/Min) G20 - 5" (NG)		15000 (BTU/h) - 4400W / 2200 (BTU/h) - 645W		
Power Rear-L, Front-R (Max/Min) G20 - 5" (NG)		18000 (BTU/h) - 5300W / 950 (BTU/h) - 275W		
Power Front-L, Rear-R (Max/Min) G31 - 10" (LP)		12000 (BTU/h) - 3500W / 2200 (BTU/h) - 645W		
Power Rear-L, Front-R (Max/Min) G31 - 10" (LP)		15000 (BTU/h) - 4400W / 950 (BTU/h) - 275W		
<b>OVEN</b>		Electric Pyro		
Type		Multifunction 2 Fans		
Temperature Regulation		Electronic		
<b>OVEN FUNCTIONS</b>				
		Pyrolytic Self-Clean with automatic door latch	Pizza (Lower Convection)	Proof (Warm)
		True European Convection Bake (Multilevel)	Bake	Broil
		Dehydrate	Thaw (Defrost)	Convection Broil
		Convection Roast	Oven Lights	Keep warm (Warm Plus)
<b>ELECTRIC OVEN FEATURES</b>				
		Preset/Last Used Temperature Memory	Preheat Indicator (25%, 50%, 75%, 100%)	Automatic Fast Preheat
		Child Door Lock	Sabbath Mode	Hour Clock Formats AM / PM
		*F Degree unit		
<b>OVEN DOOR(S)</b>				
Oven Glass Window		Deep Embossed Window		
Door Cooling System		4 Pane Heat Resistant Glasses		
Door Hinges		Heavy Duty Steady Tilt		
Handle Style		Stainless Steel Tube d30mm with Metal terminals		
<b>OVEN CAVITY</b>				
Total Capacity ( lt )		123		
Total Capacity ( cu. ft. )		4,34		
Cavity Enamel Color		Black		
Rack Positions		6		
Oven Lights		3x20W Halogen		
<b>HEATING ELEMENTS (@240V)</b>				
Broil Upper Heating Element		3500 W (240V)		
Upper Auxiliary Element Wattage		1032 W (240V)		
Concealed Bake Lower Heating Element		3000 W (240V)		
Convection Element		2 x 1300 W (240V)		
<b>OVEN ACCESSORIES</b>				
Chrome Racks		2 rack without frontal bend		
Enameled Grill set ( basin + anti splash )		1		
Telescopic Chrome Rack		Only as optional ACCESSORY		
Meat Probe		Only as optional ACCESSORY		
<b>DIMENSIONS/WEIGHT (In or Lbs)</b>				
Overall dim - Width		29 - 3/4"	758 mm	
Overall dim - Height (min - max)		39"	993 mm	
Overall dim - Depth		29 - 3/4"	756 mm	
<b>POWER / RATINGS (208/240 V, 60 HZ)</b>				
kW / Amps rating at 120-240V, 60Hz		3.84 kW - 16.9Amps		
kW / Amps rating at 120-208V, 60Hz		3.54 kW - 17.5Amps		
Power Cable		Nema 14-50P		
<b>INSTRUCTIONS FOR USE</b>				
Use & Care Manual / Installation Manual		English / French / Spanish		